

Document Detail: This is a copy of the Dan Wesson Instruction Booklet that was included with a 1978 15-2V Pistol Pac. The original has pages printed on both sides. To create this document, the booklet was unstapled and copied so that it could be printed, cut and reassembled into a single sided booklet facsimile. Each document page has four booklet pages such that the top half of the document has the front and back cover, bottom half is the second and next to last pages, etc. Cut on the lines, staple on the dots.

procedures outlined above. The hand spring fits into the slot at the rear of the hand. The trigger return spring seats on the track at the top of the trigger.

TO CHANGE FRONT SIGHT BLADE

Unscrew the front sight retaining screw (40) at the front of the shroud about one-eighth of an inch. Push the front sight blade (5) forward and then pull up, lifting the blade out of the shroud. To install the blade, place the rear dovetail at the bottom of the blade under the front sight pin (6) and tighten the front sight retaining screw.

DWA-1176-11

16

INSTRUCTION

BOOKLET



A Proud Tradition in Firearms

WELCOME to the rapidly growing family of DAN WESSON HANDGUNNERS! We're mighty pleased to have you with us, and I wish you many years of shooting pleasure with your new DAN WESSON REVOLVER.

DAN WESSON ARMS is a small but very proud company. We take a great deal of pride in the quality of the product we produce, while at the same time continuous effort is made to make even further improvements in the design and quality of our guns. Because of this, we welcome your comments — both good and bad — about our products. Many of the improvements in the revolver you just purchased were initiated by suggestions from "the field."

It is most important to us that you take whatever time is necessary to read all of the information contained in this booklet. The proper care and handling of your DAN WESSON revolver is a must, not only for reasons of safety but also for the proper functioning of your gun.

Should you ever have a problem with your revolver, we would appreciate it very much if you would let us know about it, so that the problem can be resolved as quickly as possible. Your new gun carries with it a five year warranty. We are very proud of the fact that we get very few guns back from "the field" for repair, and that those which are returned for repair are serviced promptly.

Best of luck ... and **GOOD SHOOTING!**

Very truly yours,

A handwritten signature in dark ink that reads "Dan Wesson".

Daniel B. Wesson
President

the wrench until the side plate (31) loosens and then remove the side plate.

4. Remove the hand (38).

5. Disengage the trigger return spring (41) from the trigger (39) and remove the hammer assembly (45 through 48).

6. Remove the trigger and the firing pin connector (44).

7. Remove the main spring (11) by releasing the side plate screw used to hold the main spring guide. **CAUTION:** The guide and spring will eject with considerable force when the screw is released. **MAKE SURE THE MAIN SPRING GUIDE IS POINTED IN A SAFE DIRECTION.**

8. Remove the crane lock (42).

9. Remove the cylinder assembly (32 and 33) by sliding the lower crane leg — the bottom part of the crane assembly (26) — out of the frame of the gun. The cylinder assembly may be disassembled by holding the ejector rod (22) in a padded vice jaw and unscrewing the cylinder from the ejector rod, turning in a counter-clockwise direction.

NOTE: The trigger stop screw (40) has been preset at the factory. After much use, the screw may be reset to minimize trigger overtravel.

ASSEMBLY OF LOCKWORK

Assembly procedure is the reverse of the disassembly

15

OVERTIGHTEN. Recheck the gap between the barrel and the cylinder by moving the feeler gauge from side to side. You should feel pressure against it, but it still should be able to be moved. **WARNING: THIS GAP IS CRITICAL. FAILURE TO USE THE GAUGE CAN CAUSE LEAD SPITTING.** Then remove the feeler gauge, the adapter and the wrench. After firing the first six to twelve rounds, recheck for proper barrel nut tightness and proper barrel-cylinder gap.

*If the nut is on too tight and is difficult to remove, use the following procedure. With the wrench adapter and the wrench assembled to the nut, press the muzzle of the gun firmly against the edge of a work bench. Using a hammer, give a sharp tap against the edge of the wrench to loosen the nut.

DISASSEMBLY OF LOCKWORK

(See Exploded Drawing and Parts List for Assistance)

1. Unload revolver.
2. Remove grip screw (52) using the allen wrench at the end of the wrench assembly (1) and remove the grip (50).
3. Remove the long side plate screw (30) which is exposed after the grip has been removed. With the hammer (48) in the fully cocked position, engage the long side plate screw into the main spring guide (10) through the grip screw hole. Thumb release the hammer to the fired position (fully forward). Remove the short, top side plate screw (29). Tap the grip spike on the left side with

14

Grip ... The option of changing from a round butt to a square butt frame by simply exchanging the wooden grip is a boon to the manufacturer and user alike. There are several different styles of grips available from DAN WESSON ARMS, all interchangeable, to give broad options to the user not only for hand size but also for degree of concealability. The single piece construction of the grip is durable and offers protection to the steel frame otherwise exposed to the corrosive salts from the users' hands. In addition, a one piece grip is less likely to split or break.

Front Sight ... In order to allow the shooter even greater opportunity for increased accuracy in any shooting situation, all DAN WESSON target revolvers are now equipped with interchangeable colored front sight blades. Red inserts are standard. Yellow and white are available.

QUALITY CONTROL ... Due to the relatively few machining operations involved in the manufacture of the DAN WESSON revolver, there are fewer control points to monitor, which eases the burden of control. The fact that there are fewer overall parts in the gun also contributes to better quality control through greater simplicity. Parts are designed and built to engineering specifications, which makes all but one part completely interchangeable. Knowledgeable gunsmiths and police armorers have attested to the fact that repairs are relatively simple to accomplish and require much less time than on competitive revolvers.

ACCURACY ... The accuracy of the DAN WESSON revolver has been well established and is due to its

4

IMPORTANT FEATURES

DESIGN ... The basic design of the DAN WESSON revolver was done with an eye toward modern machining practice with consideration for maintaining close tolerances, which would not accumulate to confound qualitative control and would facilitate ease of takedown. Squeeze the trigger without touching the hammer and you have rapid firepower with the shortest, fastest double-action on the market. Thumb back the hammer and squeeze off a slow, single-action shot and you will feel no creep. There are fewer parts in the DAN WESSON revolver than in any competitive revolvers.

VERSATILITY ... The concept of total versatility in design, manufacture and end use, although not new, is different from the more usual single purpose design approach. There are several facets of versatility in the DAN WESSON revolver.

Barrel ... Although most revolver barrels are changeable, the change-over on competitive guns is extremely difficult and must be done by experienced personnel and involves considerable machining and fitting. The DAN WESSON barrel is made of heat treated 4140 chrome molybdenum steel and offers total interchangeability of barrel length.

Frame ... Notice the ejector rod and front lock on your DAN WESSON. The ejector is protected by the barrel shroud and the latch is up front out of the way of your thumb while shooting. This up-front position also makes for a more positive lock where the barrel meets the cylinder. The material for the frame is the finest — 4140 investment casting.

3

serious problem which can build up to the point where it affects accuracy. Leading is removed by wire brushes and nitro solvent. Never reverse direction of the wire brush while in the barrel of the gun or chambers of the cylinder. Always push through the hole before reversing the motion of the brush. The residue from jacketed bullets is rarely a problem and is usually controlled by normal wire brushing. The cylinder center hole and upper crane leg should be cleaned at about 2,000 round intervals or whenever the cylinder rotation becomes sluggish, whichever comes first.

After cleaning the chambers of the cylinder, run a dry patch through each chamber to remove excess oil.

TO CHANGE BARREL ASSEMBLY

Unload the revolver. Assemble the wrench and adapter to the barrel nut in the muzzle of the gun. Unscrew and remove the barrel nut.* Remove the shroud by sliding it forward and off of the barrel. Unscrew the barrel from the frame. Screw the new barrel into the frame. (Note that the end of the barrel with the most threading is the end which should be screwed into the frame.) Insert the .006" feeler gauge against the front face of the cylinder and screw the barrel into the frame until there is slight pressure against the feeler gauge. Keep the gauge in place while you next assemble the shroud over the barrel and shroud locating pin (35). Next assemble the barrel nut (slots up), adapter and wrench. Hold the adapter in place firmly and tighten the nut to just that point where a firm pressure can unscrew the nut. DO NOT

13

To uncock a loaded weapon (hammer back, single action mode), place the thumb of the hand not holding the weapon between the frame and the cocked hammer. Hold the hammer back with the thumb of the other hand, pull the trigger and lower the hammer enough to release the trigger, so that it moves forward. Take your finger off the trigger, remove your thumb from between the hammer and frame and lower the hammer. In the double action mode a partially cocked hammer is let down on the frame by releasing tension on the trigger gradually, allowing the trigger to slowly move forward.

The proper method of holding a revolver is highly influenced by the size of your hands, the "power" (weight and velocity of the projectile) of the cartridge you choose to shoot and the style or styles (positions) of shooting you choose. As a general rule, the more powerful the load is, the tighter the grip must be. DAN WESSON ARMS offers several styles of interchangeable one-piece grips as well as an inletted blank for those who prefer to customize a grip to their own hands.

CLEANING

A revolver should be kept clean and lightly oiled. Firing leaves a residue of powder. Leading can be caused by firing too soft a lead bullet, improper lubrication of the bullet, too high a velocity or by a combination of these factors. Jacketed bullets also leave a residue in the barrel.

Powder residue can be easily removed by swabbing out the barrel with any of the well known powder solvents and a soft bristle brush. Leading is a more

12

accumulating with lubricants to form a clinging mass of foreign material to hamper operation.

SAFETY ... The DAN WESSON revolver can be fired only when the trigger is retracted to the firing position. Therefore, if the weapon is dropped, even though in the cocked position, it cannot fire even if the hammer drops off the notch. This is due to the fact that the trigger will recover faster than the hammer drops, and thereby "safeties" the revolver automatically. The safety mechanism is "fail safe" in design in that the removal of the firing pin connector will prevent the hammer from contacting the firing pin.

SAFETY PRECAUTIONS

In order to become a **good** shooter you must first be a **safe** shooter! Although shooting is a sport and recreation, it demands **strict compliance with the rules of safety**. Below is a list of safety precautions which we ask that you learn and observe:

1. Always consider the revolver to be loaded until you have personally checked to see that the chambers of the cylinder are empty.
2. Never point a gun — loaded or unloaded — at anyone or anything that you do not intend to shoot.
3. Always unload the revolver before allowing anyone else to handle it.

6

design and the manufacturing techniques utilized in the production lines. The reasons for the great accuracy of the DAN WESSON revolver are as follows: (1) It is the only revolver in which the barrel is secured at both ends. (2) It is the only revolver in which the barrel is under tension. (3) The cylinder latch is located up front, as close as possible to the barrel-cylinder gap for increased stability. (4) The muzzle of the barrel is flat, not rounded or crowned.

STRENGTH ... Design, choice of materials and manufacturing techniques have all contributed to the pressure safety factor of DAN WESSON revolvers. Test results have shown the DAN WESSON to be capable of withstanding operating pressures in excess of competitive revolvers.

DURABILITY ... Among those knowledgeable in revolvers, it is a well known fact that they are extremely sensitive to rough handling or dropping. Generally, the cylinder will bind up making firing impossible. The DAN WESSON revolver can be dropped to produce impact in any direction and will generally function normally following such abuse.

RELIABILITY ... Again, because of design and manufacturing techniques, the DAN WESSON revolver will withstand a greater accumulation of foreign materials such as sand, grit, mud, etc. than will those of other manufacture. The design is such that no lubrication is required for proper weapon function. This not only aids in below freezing weather, but also in low humidity/high dust conditions by reducing the likelihood of sand

5

factory-loaded ammunition of reputable manufacture.

LOADING

Do not try to open the cylinder with the trigger back, as the hand overlaps the extractor and locks the cylinder in position.

The cylinder opens to the left by pushing the latch down and pressing the right rear side of the cylinder to clear the cylinder aligning ball.

Load the open cylinder, using the proper ammunition, with the muzzle pointing downward. Then close the cylinder to engage the latch and the cylinder is locked in position.

UNLOADING

Open the cylinder, point the muzzle up and press the ejector rod to remove the cartridges.

SHOOTING

Single action firing is accomplished by thumbing back the hammer all the way to the rear, engaging the hammer and trigger sear. Pressing the trigger will disengage the sear, letting the hammer fall to fire the cartridge.

Double action firing is accomplished by pulling the trigger back until the hammer falls.

Working the action without cartridges in the cylinder in either single or double action (dry firing) will not harm the weapon.

11

12. If your revolver fails to function properly, STOP FIRING and don't use the revolver again until it does function properly.

13. Store your revolver and ammunition separately and beyond the reach of children.

14. Never leave a loaded gun lying about. Never leave a gun in an automobile.

15. When hunting, walking, climbing or any time you are following someone, keep your revolver in its holster.

16. Use clean, dry factory-loaded ammunition of the proper size and caliber.

17. We strongly suggest that the shooter and those in his immediate vicinity wear proper ear and eye protection devices during firing. Repeated and prolonged exposure to heavy noise levels of firing without adequate ear protection may result in hearing losses which may not be immediate and are accumulative.

AMMUNITION

DAN WESSON .357 Magnum revolvers are chambered to fire the .357 Magnum cartridge and will also fire .38 Special cartridges interchangeably. DAN WESSON .38 Special revolvers, however, are chambered only for .38 Special cartridges. The cylinders on these revolvers will not accept .357 Magnum cartridges. (For easy reference, the caliber of each revolver is marked on the side of the barrel shroud.) We recommend the use of good, clean

10

4. Don't put your finger on the trigger, or even inside the trigger guard, until you are actually aiming at a target and prepared to fire.

5. Always hold your gun so that the muzzle is under control at all times — even if you slip or fall — and pointed in a safe direction.

6. When at a range, always carry your revolver with the cylinder open or the gun holstered and unloaded.

7. Immediately before dry firing, cleaning, disassembly or storage, check to make sure the revolver is unloaded.

8. Prior to firing make certain there are no obstructions in the barrel or action of your revolver. If there are, clean the gun immediately.

9. WARNING: IMPROPER BARREL - CYLINDER CLEARANCE CAN CAUSE LEAD SPITTING. PROPER SPACING IS ACHIEVED BY USE OF THE .006 GAUGE PROVIDED WITH EACH GUN. (SEE BARREL CHANGING INSTRUCTIONS ON PAGE 13).

10. Before commencing target practice, check to be certain that the target backstop is adequate to stop and contain bullets.

11. Do not shoot at a flat or hard surface. Bullets may ricochet, for example, off of rocks or even the surface of water.

7

PARTS LIST FOR

DAN WESSON
Model 14-2 Service
Model 15-2 Target

1. Wrench
2. Gauge, Bbl. & Cyl. Clearance
3. Wrench Adapter
4. Barrel Nut
5. Front Sight
6. Front Sight Pin
7. Shroud
8. Barrel
9. Frame
10. Main Spring Guide
11. Main Spring
12. Firing Pin Retaining Pin
13. Rear Sight Elevation Tension Spring
14. Rear Sight Elevation Screw
15. Rear Sight Body
16. Rear Sight Retaining Pin
17. Firing Pin Spring
18. Firing Pin
19. Cyl. Aligning Ball
20. Spring, Cylinder Aligning Ball
21. Aligning Ball Screw
22. Ejector Rod
23. Latch Retaining Pin
24. Latch
25. Latch Spring
26. Crane
27. Ejector Rod Bushing
28. Ejector Spring

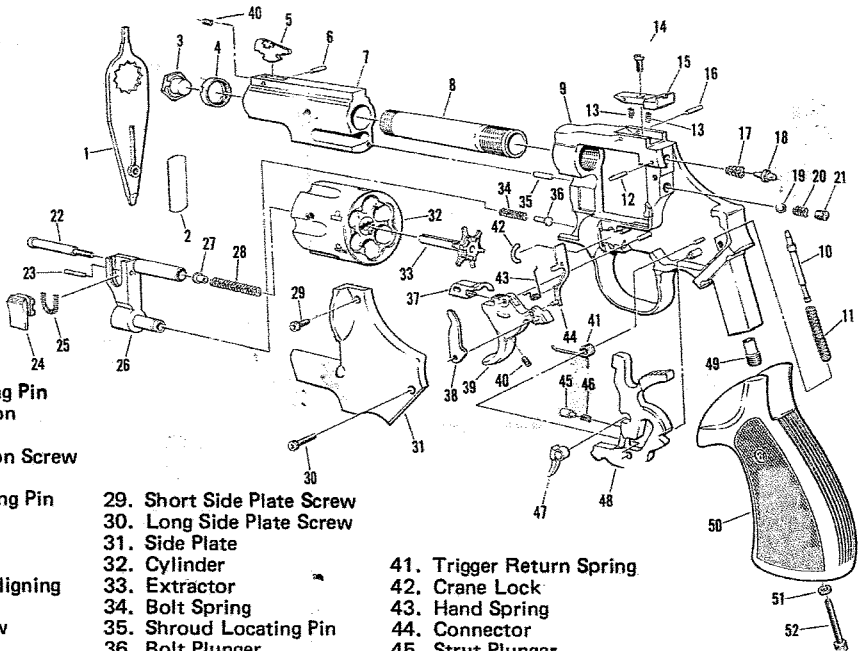

29. Short Side Plate Screw
30. Long Side Plate Screw
31. Side Plate
32. Cylinder
33. Extractor
34. Bolt Spring
35. Shroud Locating Pin
36. Bolt Plunger
37. Bolt
38. Hand
39. Trigger
40. Trigger Stop Screw and Interchangeable Front Sight Retaining Screw

41. Trigger Return Spring
42. Crane Lock
43. Hand Spring
44. Connector
45. Strut Plunger
46. Strut Spring
47. Strut
48. Hammer
49. Mainspring Seat
50. Grip
51. Grip Screw Washer

52. Grip Screw